

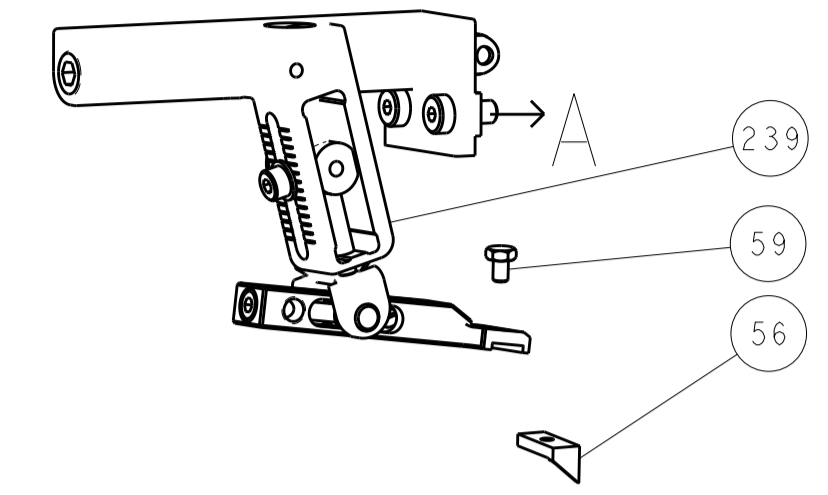

LOC		DIST		REVISIONS			
A	66	P	LTH	DESCRIPTION	DATE	DWN	APVD
		-		SEE SHEET 1			

### FEED TYPE MECHANICAL



### PNEUMATIC

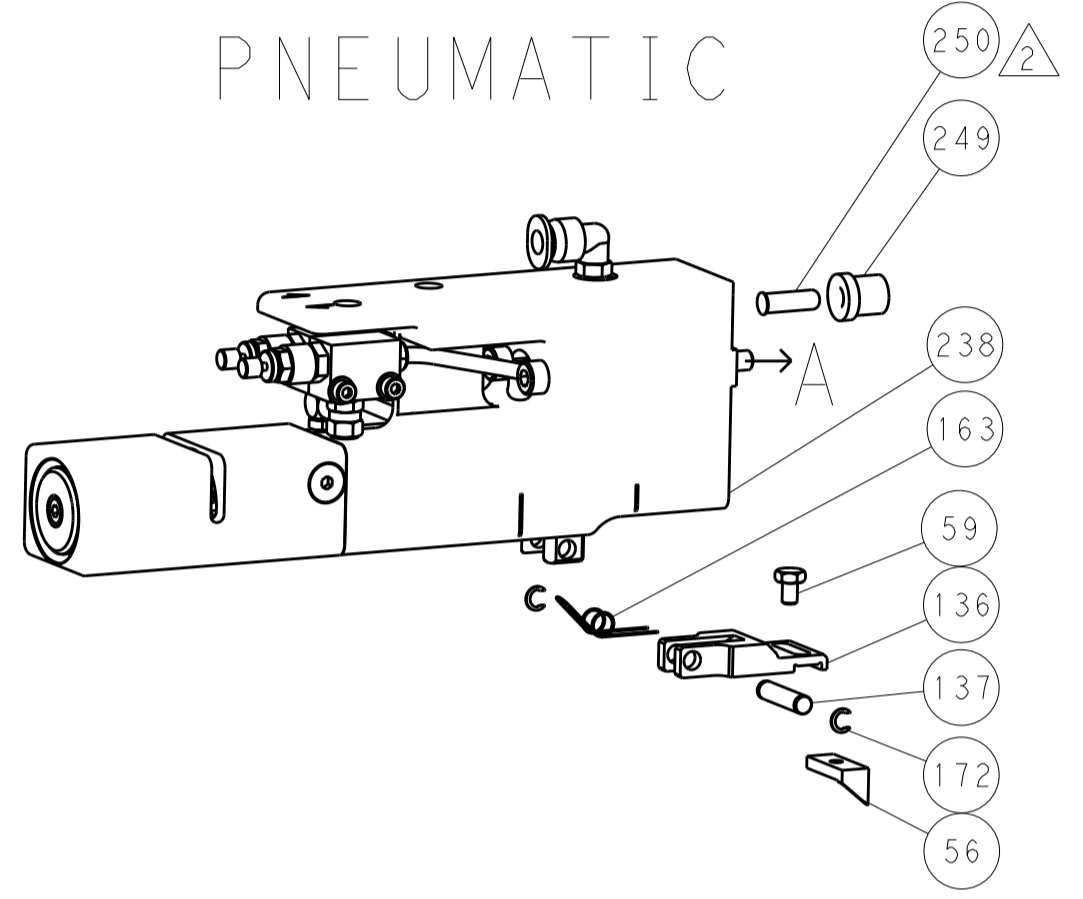

### SERVO LATCH PLATE

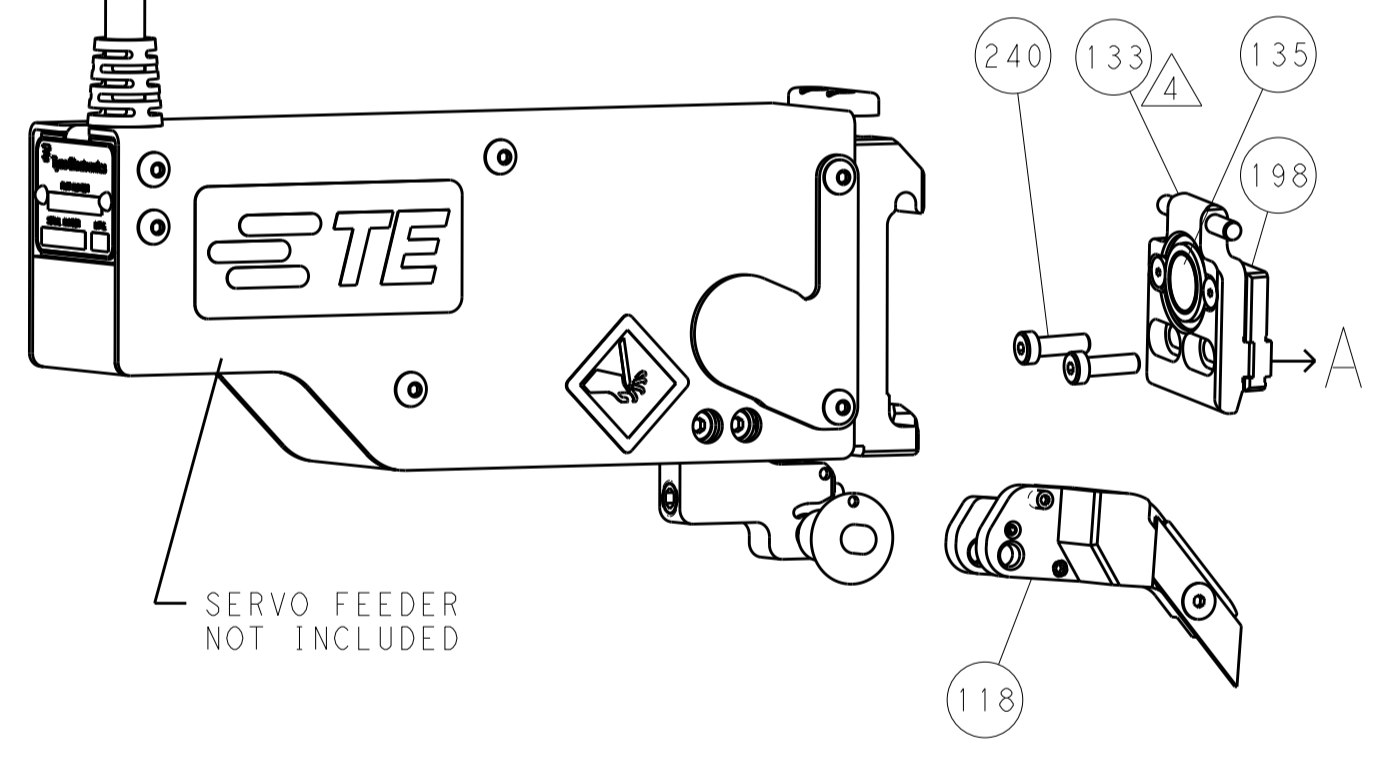

### CAM POSITIONS

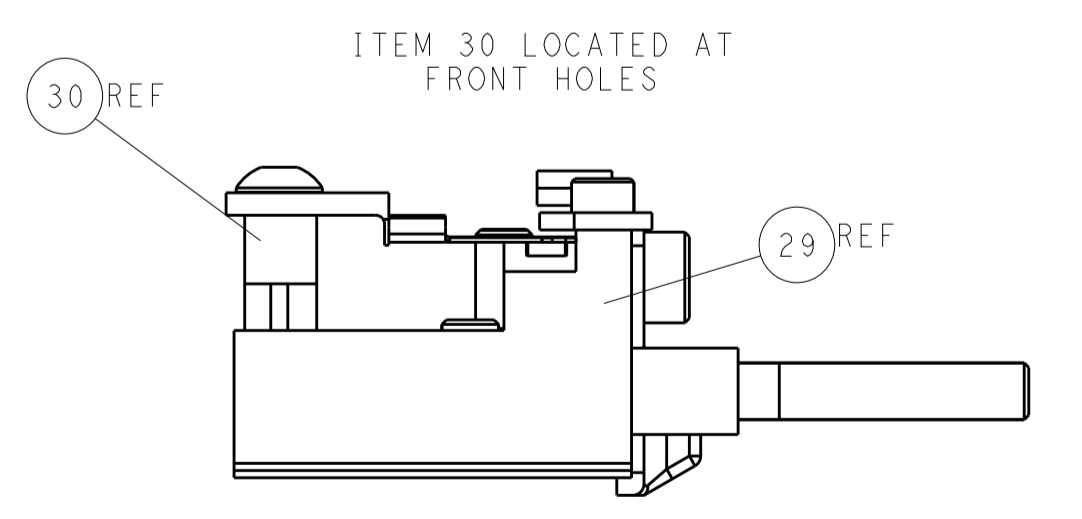
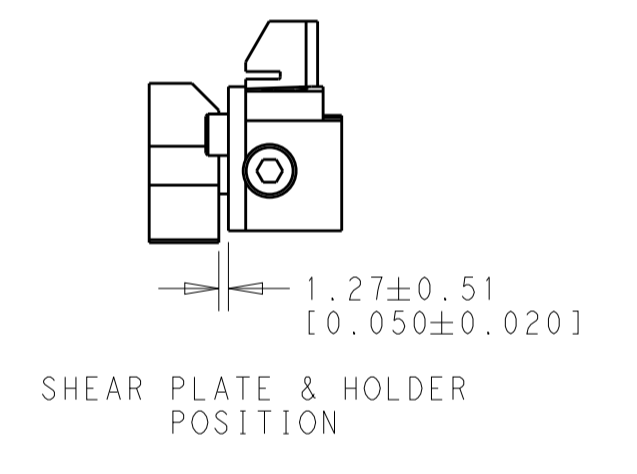
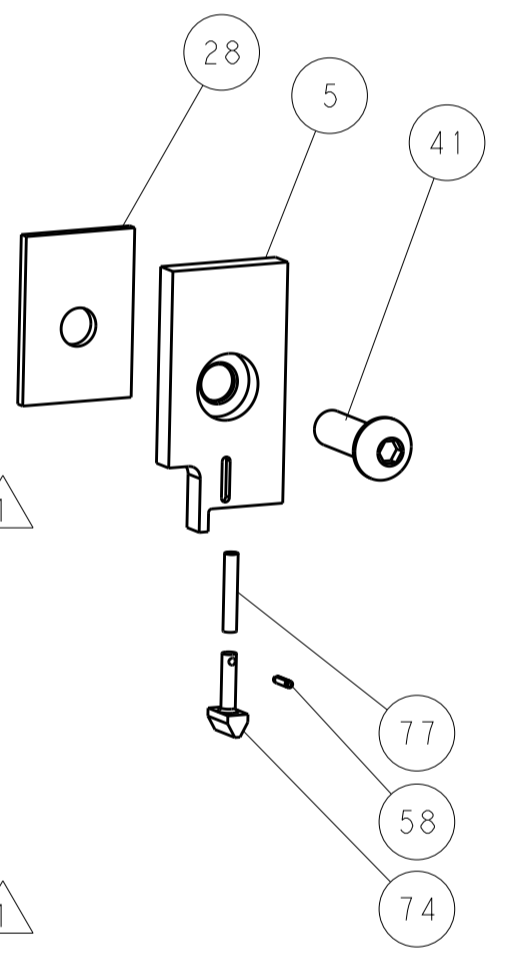
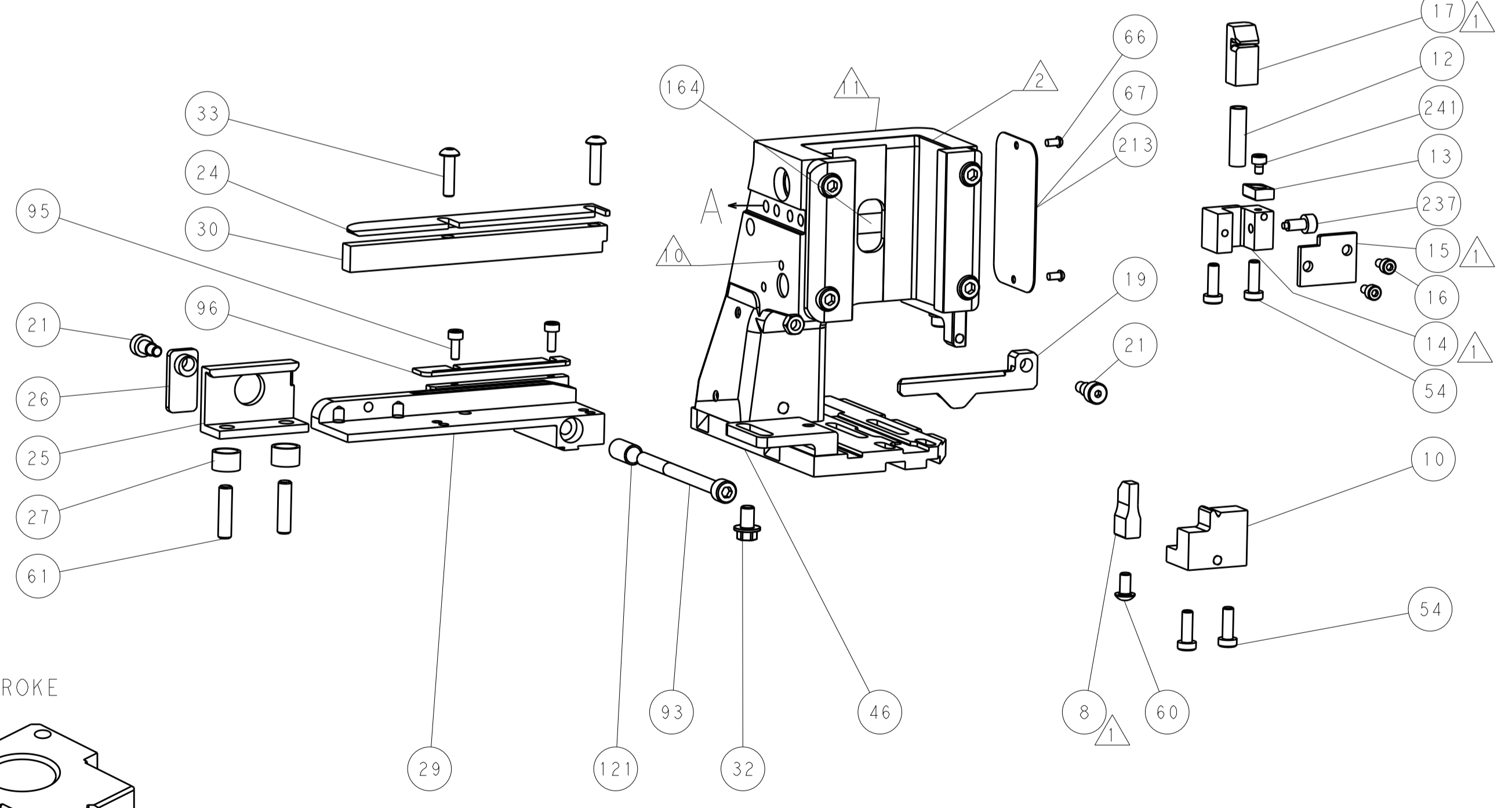
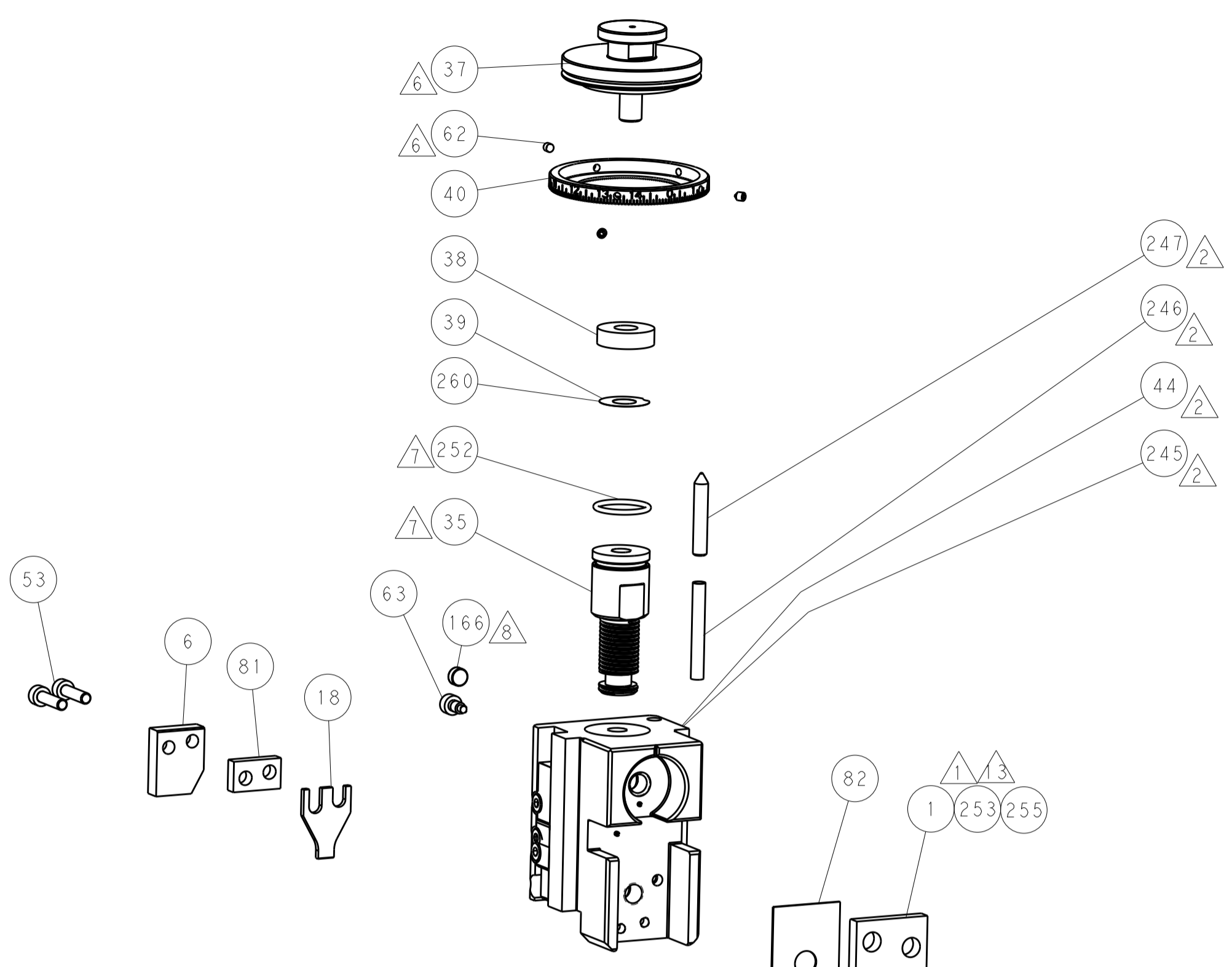
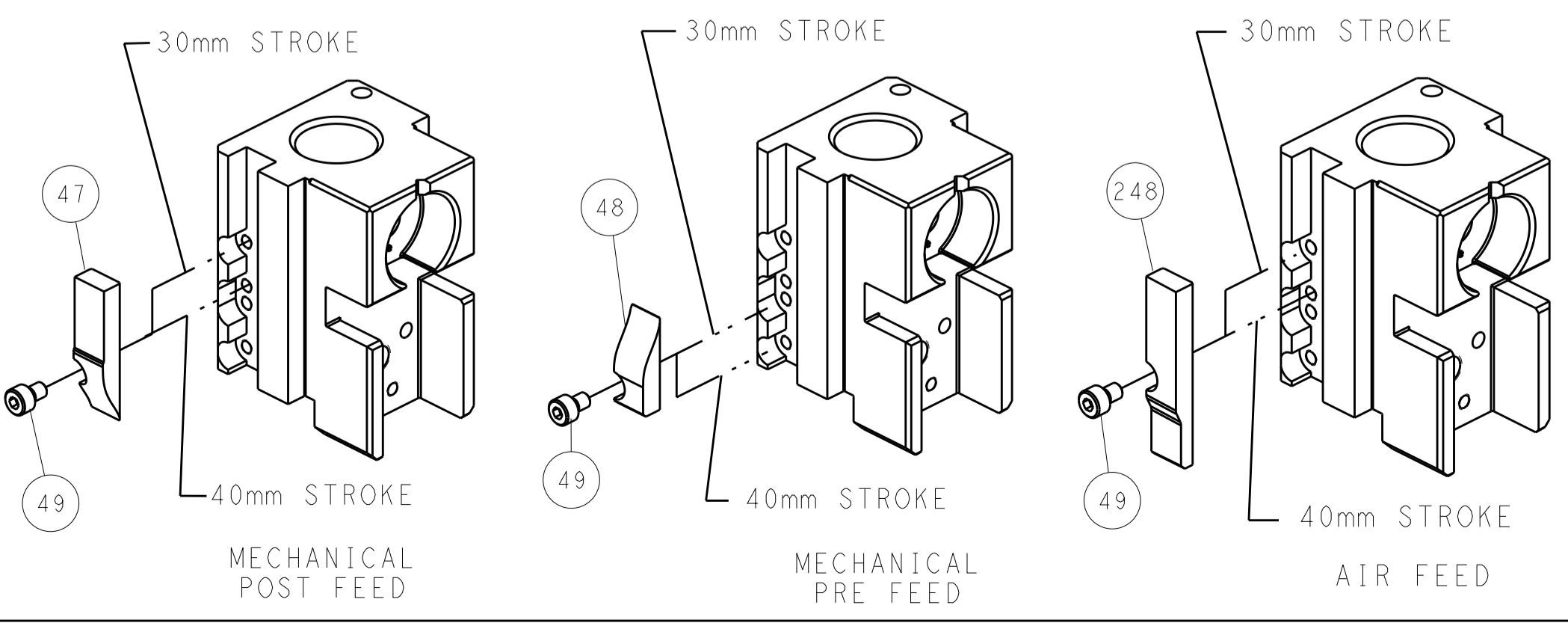

**ATLANTIC VERSION**  
 Shown on sheets 1 of 4 & 2 of 4  
 (Pacific version shown on sheets 3 of 4 & 4 of 4)

DIMENSIONS:		TOLERANCES UNLESS OTHERWISE SPECIFIED:		DWN R. KNEPPER 25APR2013		TE Connectivity	
mm	0 PLC ±0.5	1 PLC ±0.5	2 PLC ±0.13	3 PLC ±0.013	4 PLC ±0.001	CHG T. ELBIN 25APR2013	Harrisburg, PA 17105-3608
MATERIAL:		FINISH:		APVD M. CLIFFORD 25APR2013		NAME Ocean Side Feed Applicator	
				PRODUCT SPEC:		SIZE CAGE CODE DRAWING NO RESTRICTED TO	
				APPLICATION SPEC:		A11 00779 ©=2151914	
				WEIGHT:		Customer Accessible Production Drawing SCALE 1:2 SHEET 2 of 4 REV A	



LOC		DIST		REVISIONS			
A	66	P	LTM	DESCRIPTION	DATE	DWN	APVD
		-	-	SEE SHEET 1	-	-	-

# FEED TYPE MECHANICAL

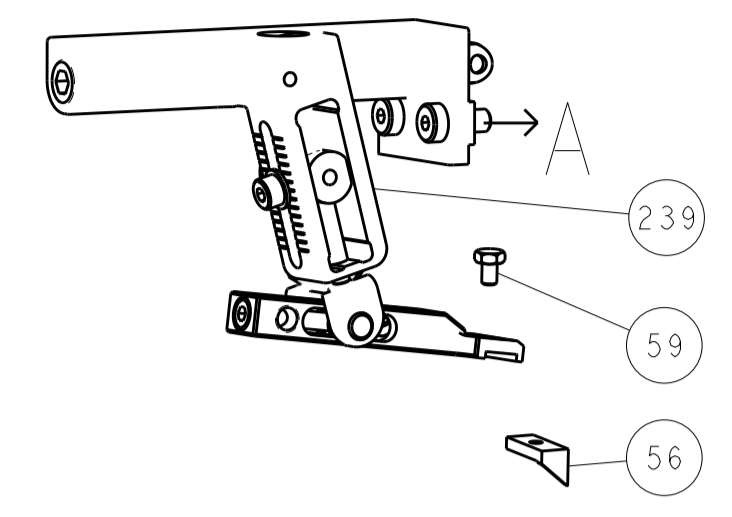

# PNEUMATIC

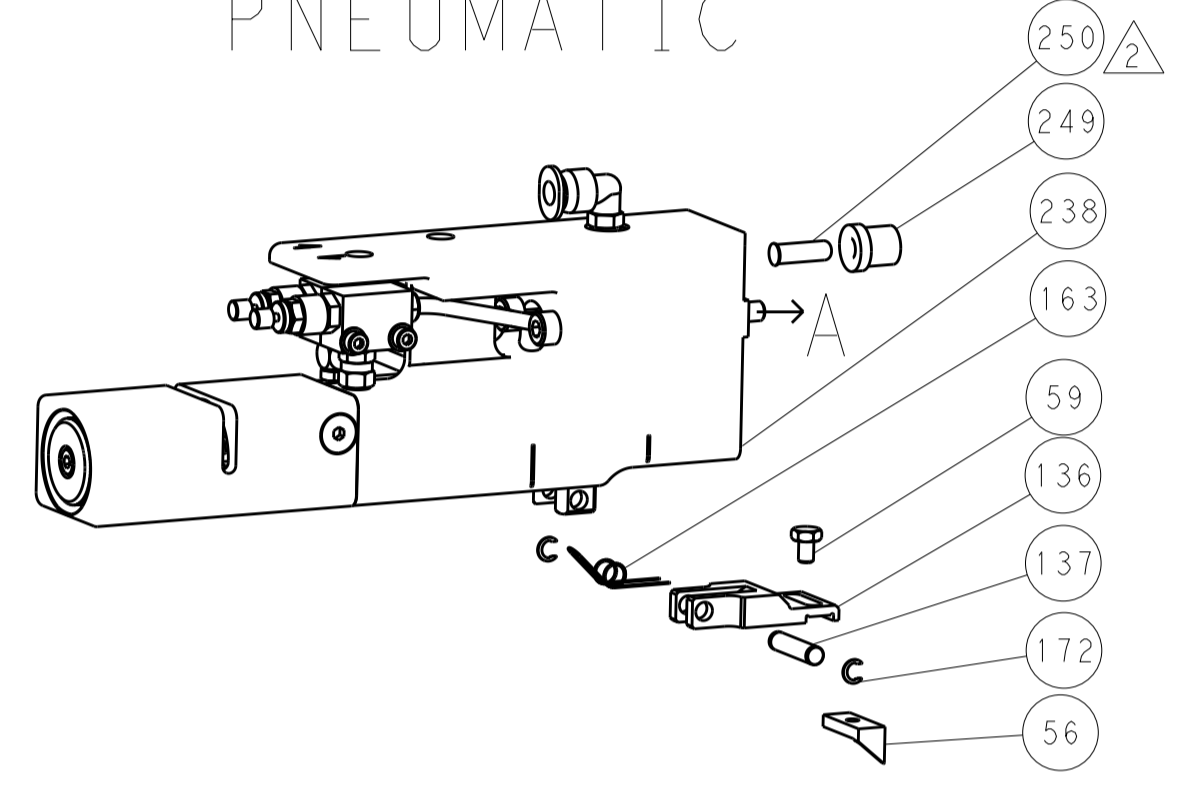

# SERVO LATCH PLATE

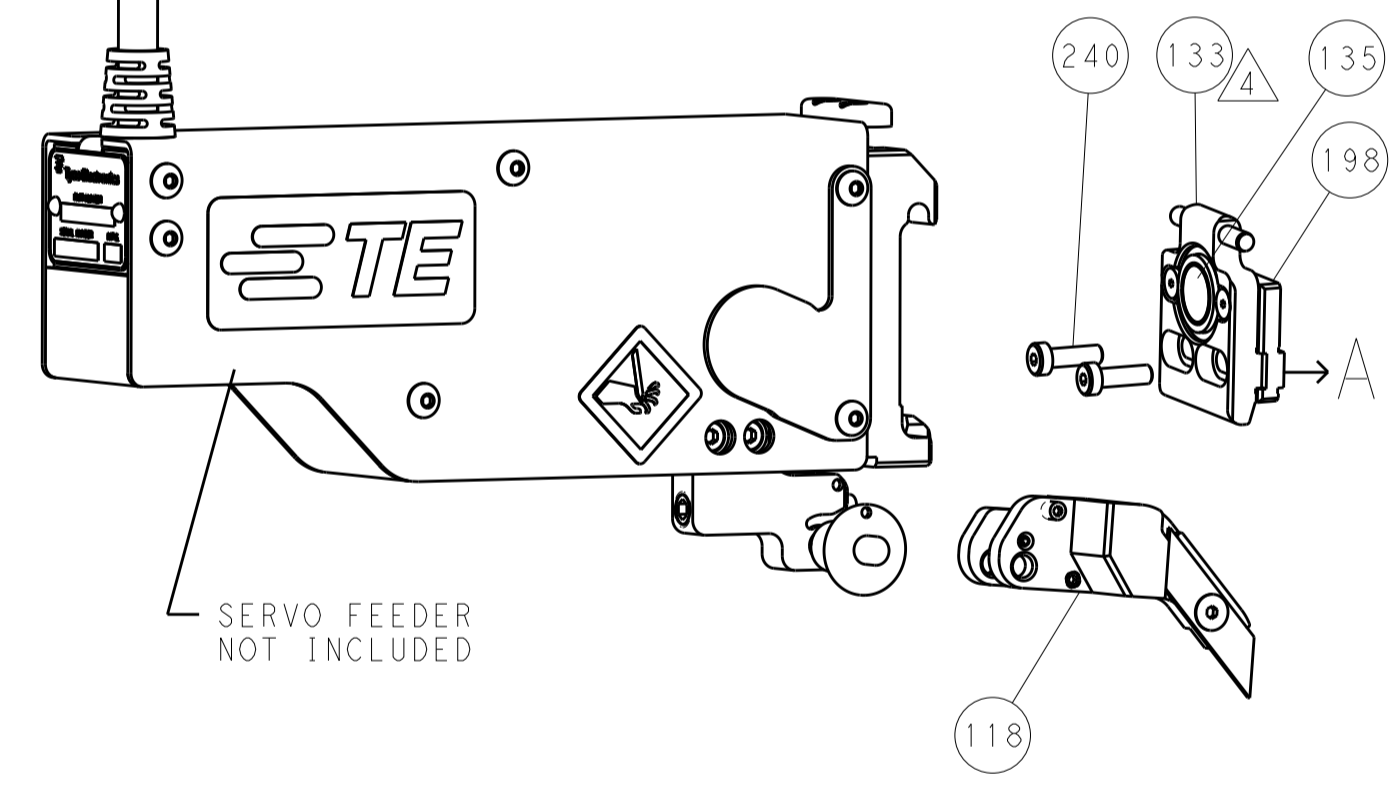

# CAM POSITIONS

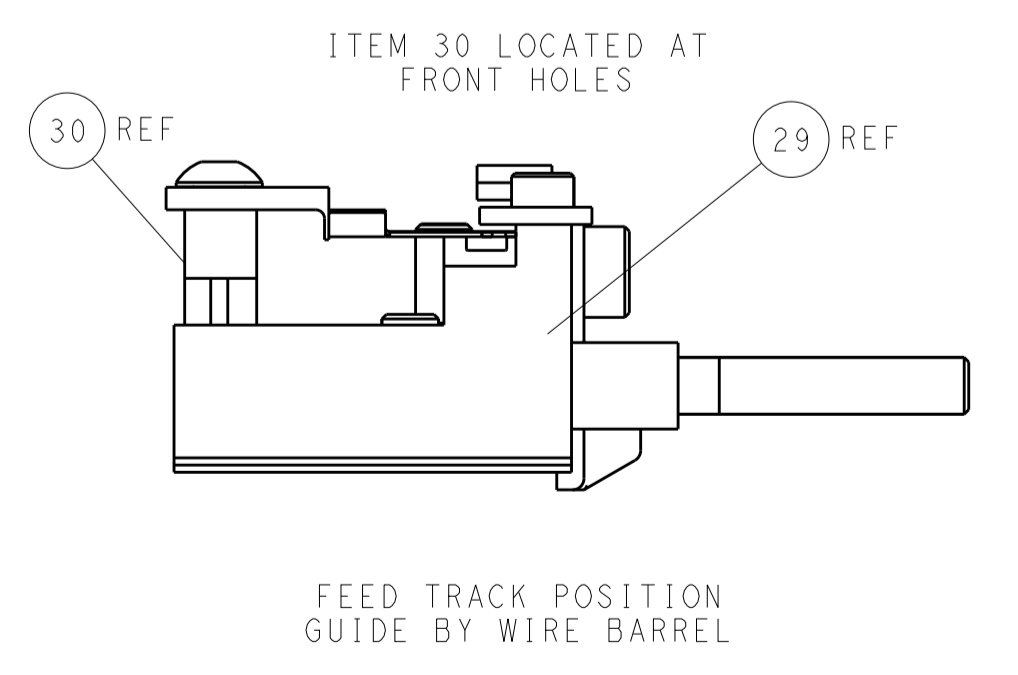
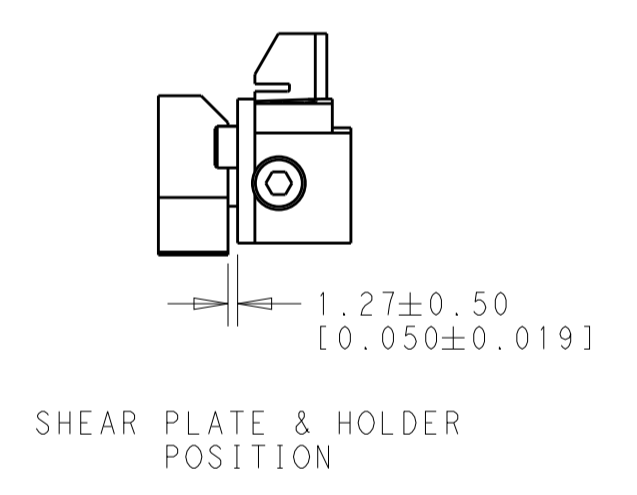
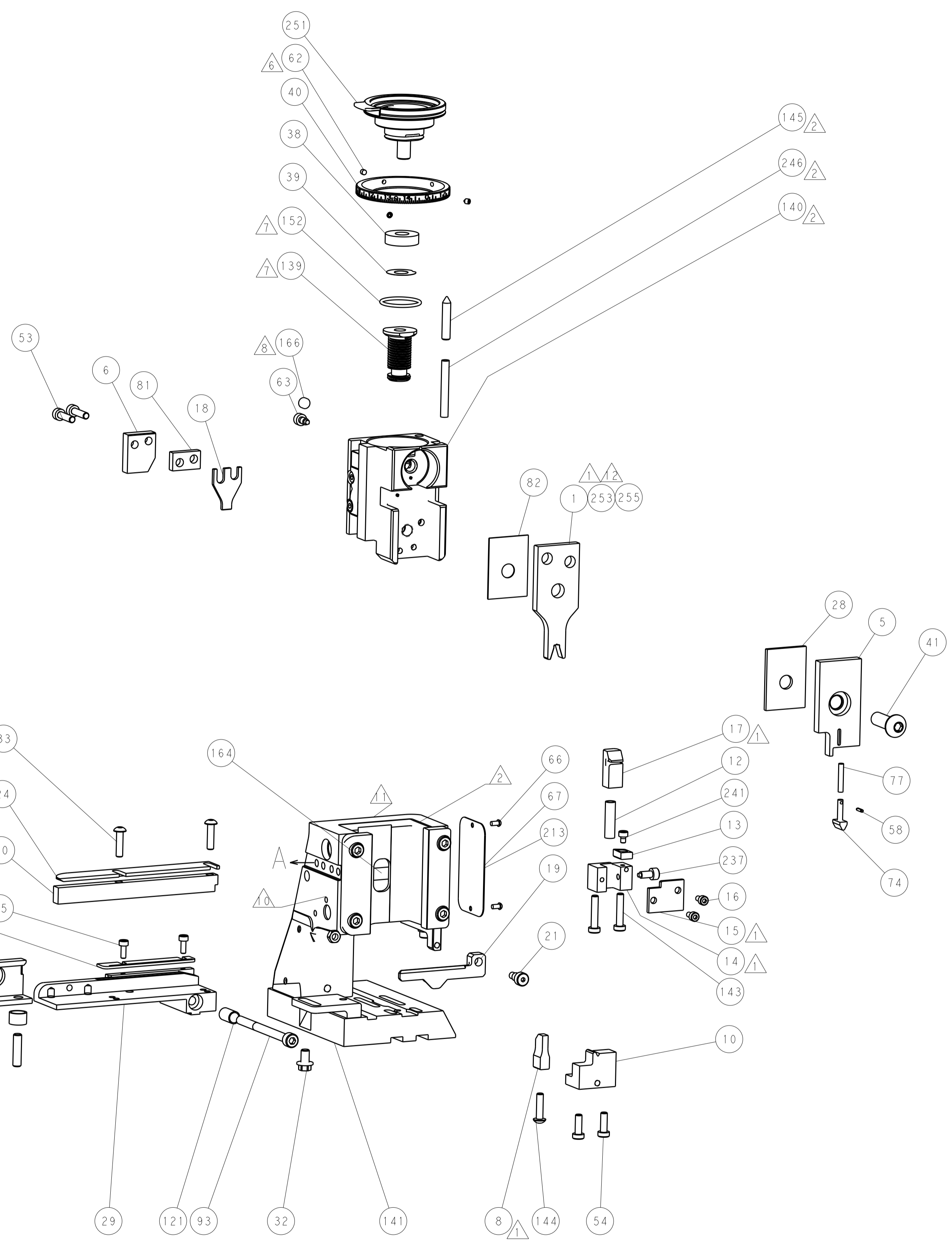
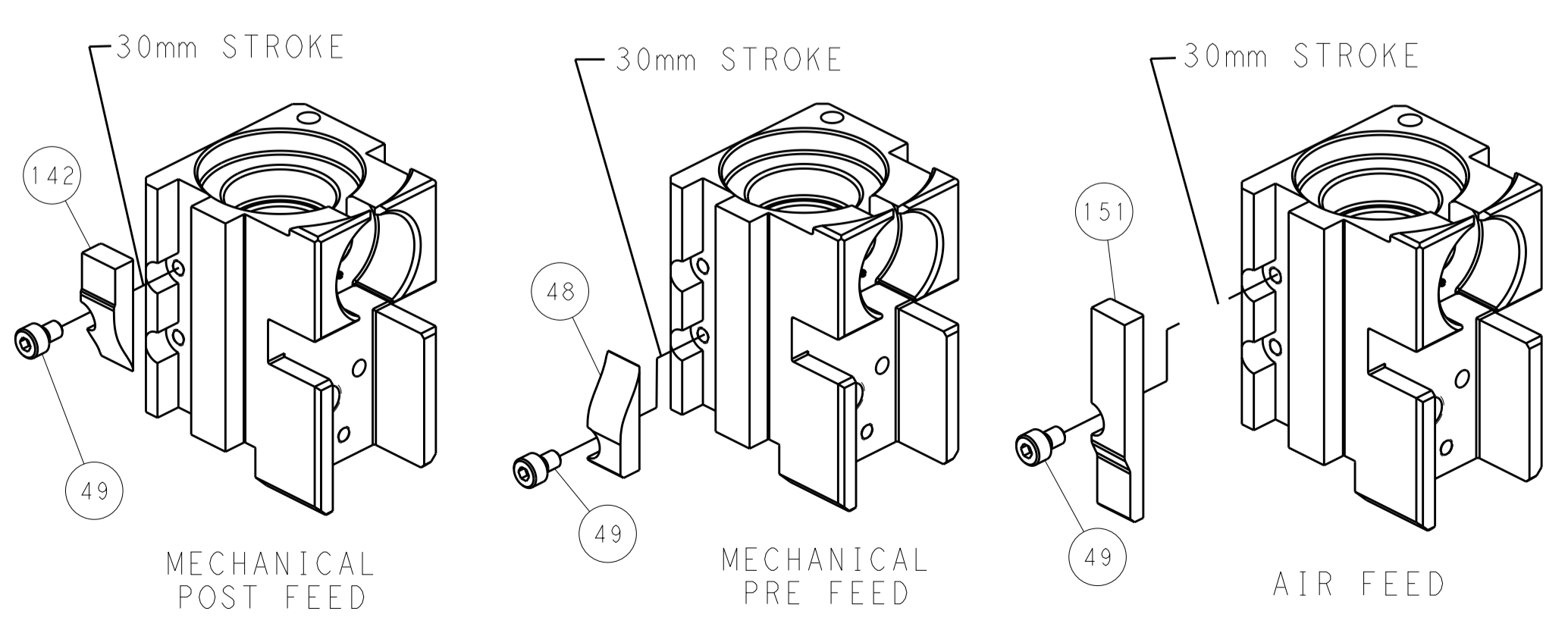

**PACIFIC VERSION**  
 Shown on sheets 3 of 4 & 4 of 4  
 (Atlantic version shown on sheets 1 of 4 & 2 of 4)

DIMENSIONS: mm 		TOLERANCES UNLESS OTHERWISE SPECIFIED: 0 PLC ±0.5 1 PLC ±0.13 3 PLC ±0.013 4 PLC ±0.001 ANGLES ±0.001		DWN R. CLIFFORD 25APR2013 CHK T. ELBIN 25APR2013 APVD M. CLIFFORD 25APR2013		NAME Ocean Side Feed Applicator SIZE CAGE CODE DRAWING NO. A1 00779 C=2151914 RESTRICTED TO	
MATERIAL		FINISH		WEIGHT		SCALE 1:2 SHEET 4 OF 4 REV A	