

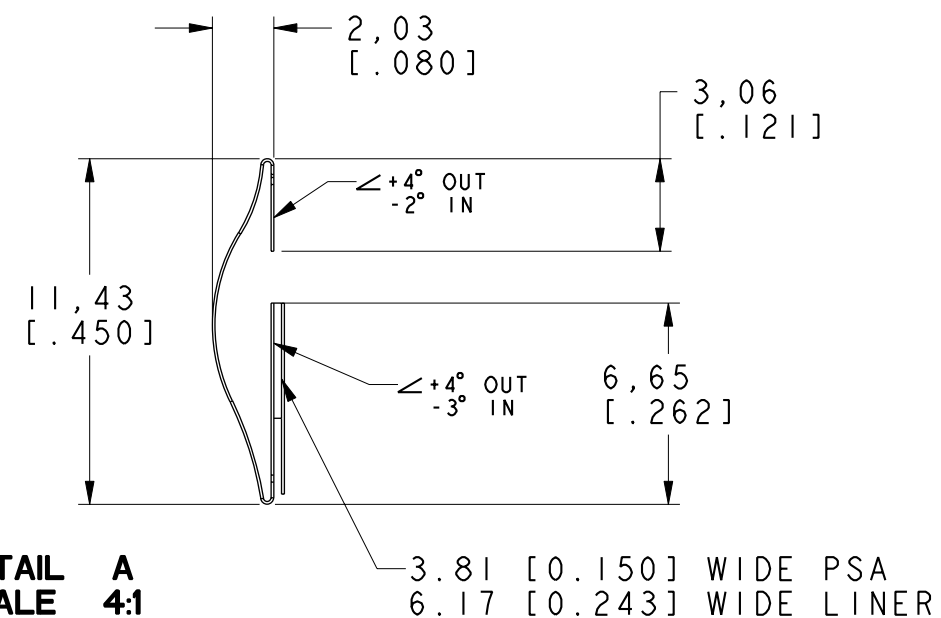

DWG. NO.	0077-0043	
REVISIONS		
ECO-E731 & E766. ADDED TAPE, PILOT HOLES, AND HT SHRINKAGE. DELETED WIDTH. RKM 02/25/99 EWS 3/1/99		02
REMOVED 1/2 SLOT FROM BOTH ENDS 15.982±.025 LENGTH WAS 16.000±.187 ECO - #E792 AD 03/10/99 EWS 03/15/99		03
ADDED EXTENDED LINER TO PSA ON DRAWING ECO #E870 AD 04/29/99 EWS 04/29/99		04
ADDED ANGULAR TOLERANCE ON LEGS ECO #E940 AD 06/03/99 EWS 06-07-99		05
ECO-E5841 UPDATED TOL BLOCK SDH 03/06/07 EWS 03/06/07		06

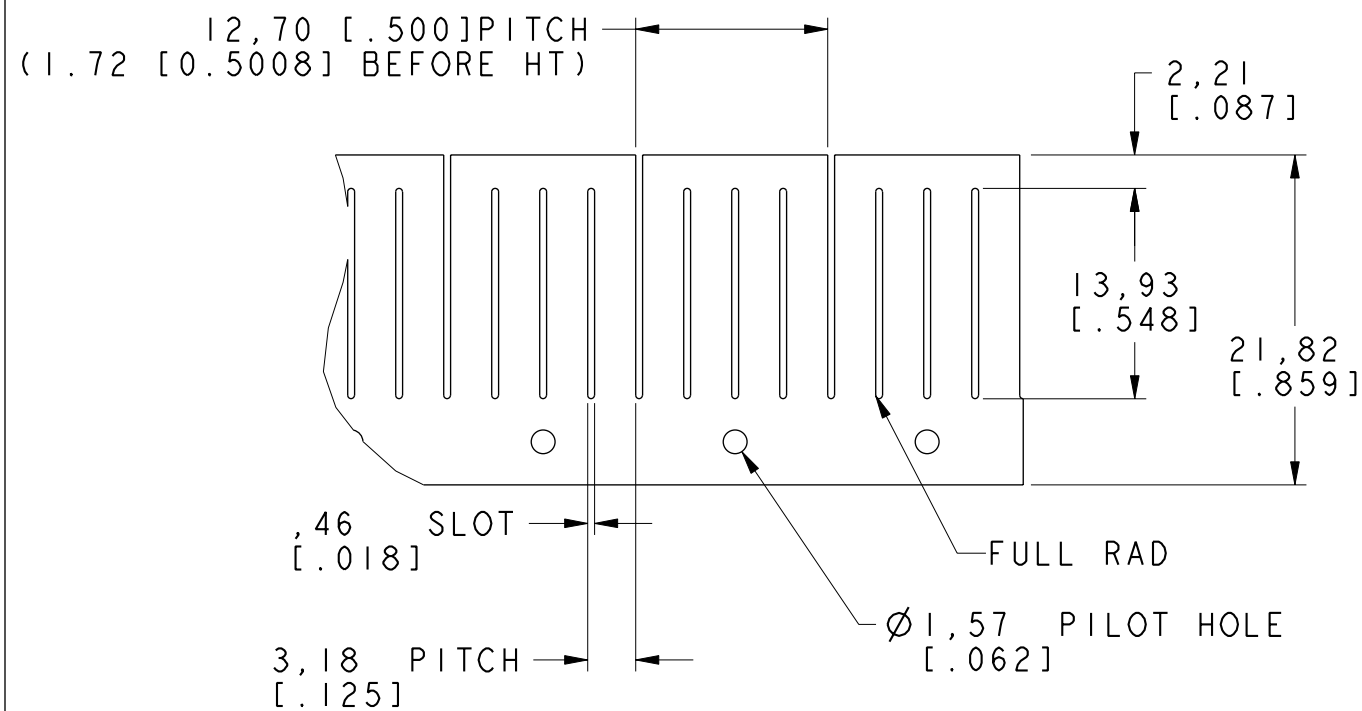
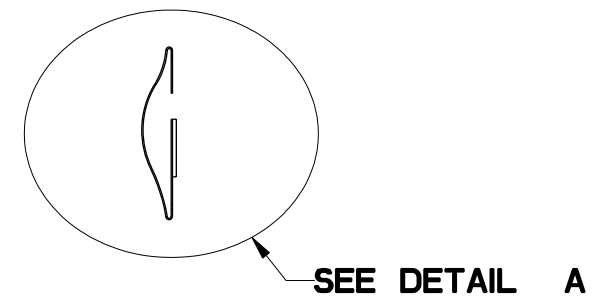
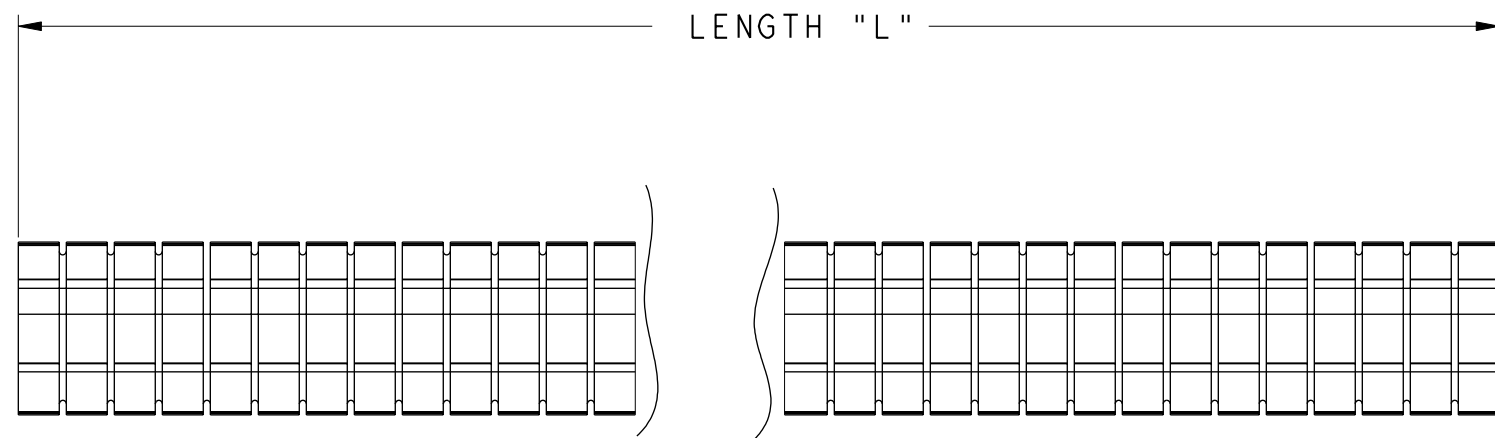

FLAT PATTERN
SCALE 2:1
TOL.± 0.013 [0.0005] ON
ALL DIMENSIONS

DETAIL A
SCALE 4:1

MATERIAL: 0.09 [0.0035] ±0.005 [0.0002] BeCu ALLOY 25 1/4 HARD	TOLERANCES NOT SHOWN		 LAIRD STANDARD DELAWARE WATER GAP PENNSYLVANIA	DRAWN BY: JAS	DATE: 12/22/98
	DECIMAL 2 PL'S ± .25 [0.010]			CHECKED: EWS	DATE: 12/22/98
HEAT TREAT: TO DPH 383 MIN USING A 500 GRAM LOAD	ANGULAR ± 3°		APPROVED:	DATE:	
THICKNESS AFTER: CLEANING 0.08 [0.0031] MIN	THIRD ANGLE PROJECTION	REF. DWG NO.		DWG. NO. 0077-0043	
FINISH: AS REQUIRED	UNITS: MM [INCH]	SCALE: 2:1	REV 06		SHEET 1 OF 1
CAD MAINTAINED DRAWING. MANUAL CHANGES UNAUTHORIZED.					

THIS INFORMATION IS CONFIDENTIAL AND PROPRIETARY TO LAIRD TECHNOLOGIES. IT MAY NOT BE DISCLOSED TO ANYONE, OTHER THAN LAIRD TECHNOLOGIES PERSONNEL, WITHOUT WRITTEN AUTHORIZATION FROM LAIRD TECHNOLOGIES.

DWG. NO. 0077-0043