

ASSEMBLY INSTRUCTIONS:

1. PREPARE CABLE AS REQUIRED TO ASSEMBLE TO THE CONNECTOR
2. CHOOSE THE STRAIN RELIEF HALVES THAT MOST CLOSELY MATCH THE CABLE O/D AND PLACE ONE INTO EACH RECESS. THEY DO NOT NEED TO BE MATCHING HALVES
3. PLACE THE CABLE INTO THE STRAIN RELIEF IN ONE HALF OF THE PLASTIC HOOD. ENSURE THE CABLE IS PRESSED INTO THE STRAIN RELIEF PIECE
4. SNAP THE JACKSCREWS INTO POSITION
5. PLACE THE OTHER HALF OF THE PLASTIC HOOD INTO PLACE AND TIGHTEN TOGETHER WITH THE ASSEMBLY SCREWS AND NUTS

SEE PAGES 3 AND 4 FOR THE 50 POSITION DIE CAST ASSEMBLY INSTRUCTIONS

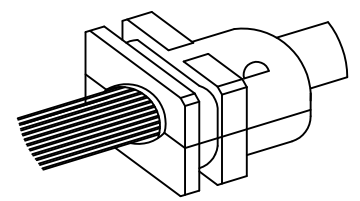
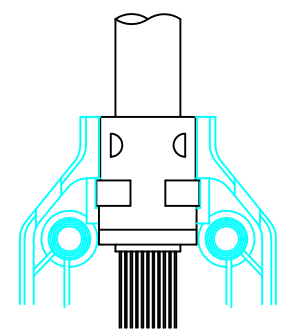
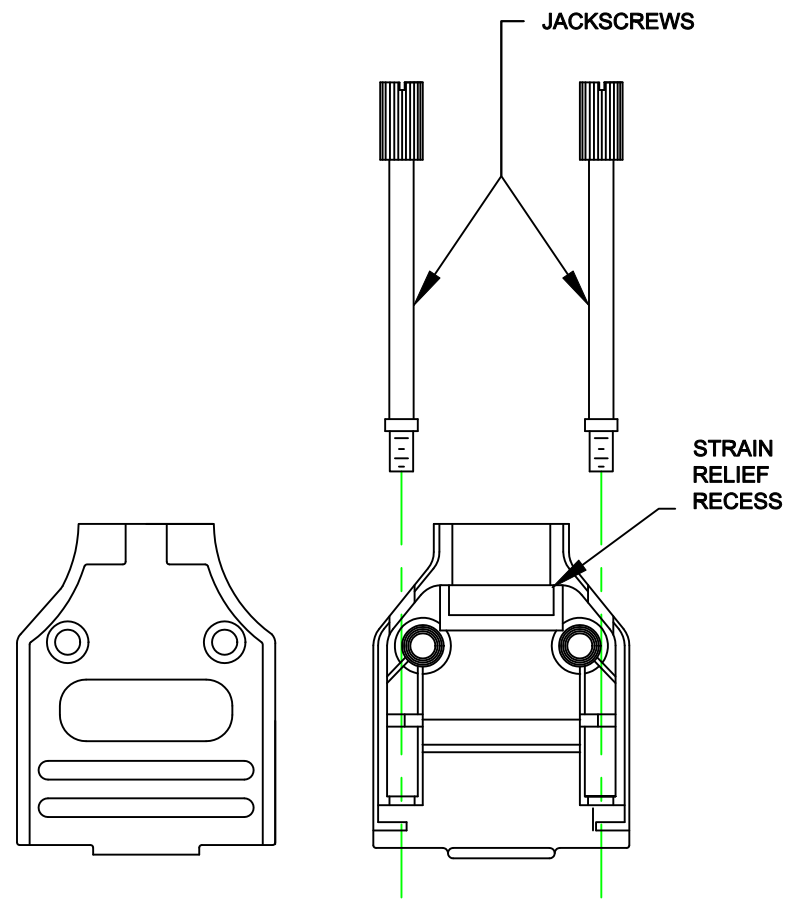

CABLE WITHOUT SHIELD OR GROUND

RoHS COMPLIANT

PLASTIC

	THESE DRAWINGS AND SPECIFICATIONS ARE THE PROPERTY OF NorComp AND SHALL NOT BE REPRODUCED, COPIED OR USED AS THE BASIS FOR THE MANUFACTURE OF SALE OF APPARATUS WITHOUT WRITTEN PERMISSION.		DRAWN: C. SMITH	DATE: 03-20-06	
			CHECKED: X	DATE: X	
<h1>NorComp</h1>			SCALE: N.T.S.	SHEET 1 OF 4	REV 1
			DWG NO. BACKSHELL - 970 SERIES		

ASSEMBLY INSTRUCTIONS:

1. PREPARE CABLE AS REQUIRED TO ASSEMBLE TO THE CONNECTOR
2. CHOOSE THE STRAIN RELIEF HALVES THAT MOST CLOSELY MATCH THE CABLE O/D AND PLACE ONE INTO EACH RECESS. THEY DO NOT NEED TO BE MATCHING HALVES
3. USE THE METAL SHIELD SUPPORT TO ISOLATE THE BRAID/DRAIN WIRE TO THE DIE CAST SHELL
4. PLACE THE CABLE ASSEMBLY/SHIELD SUPPORT INTO THE APPROPRIATE RECESS IN ONE HALF OF THE DIE CAST HOOD. ENSURE THE CABLE IS PRESSED INTO THE STRAIN RELIEF PIECE
5. SNAP THE JACKSCREWS INTO POSITION
6. PLACE THE OTHER HALF OF THE DIE CAST HOOD INTO PLACE AND TIGHTEN TOGETHER WITH THE ASSEMBLY SCREWS

SEE PAGES 3 AND 4 FOR THE 50 POSITION DIE CAST ASSEMBLE INSTRUCTIONS

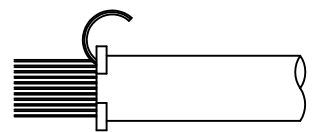
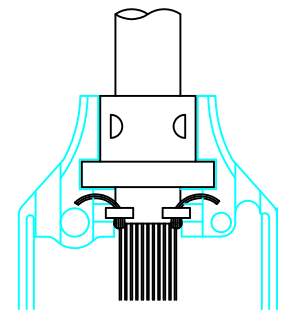
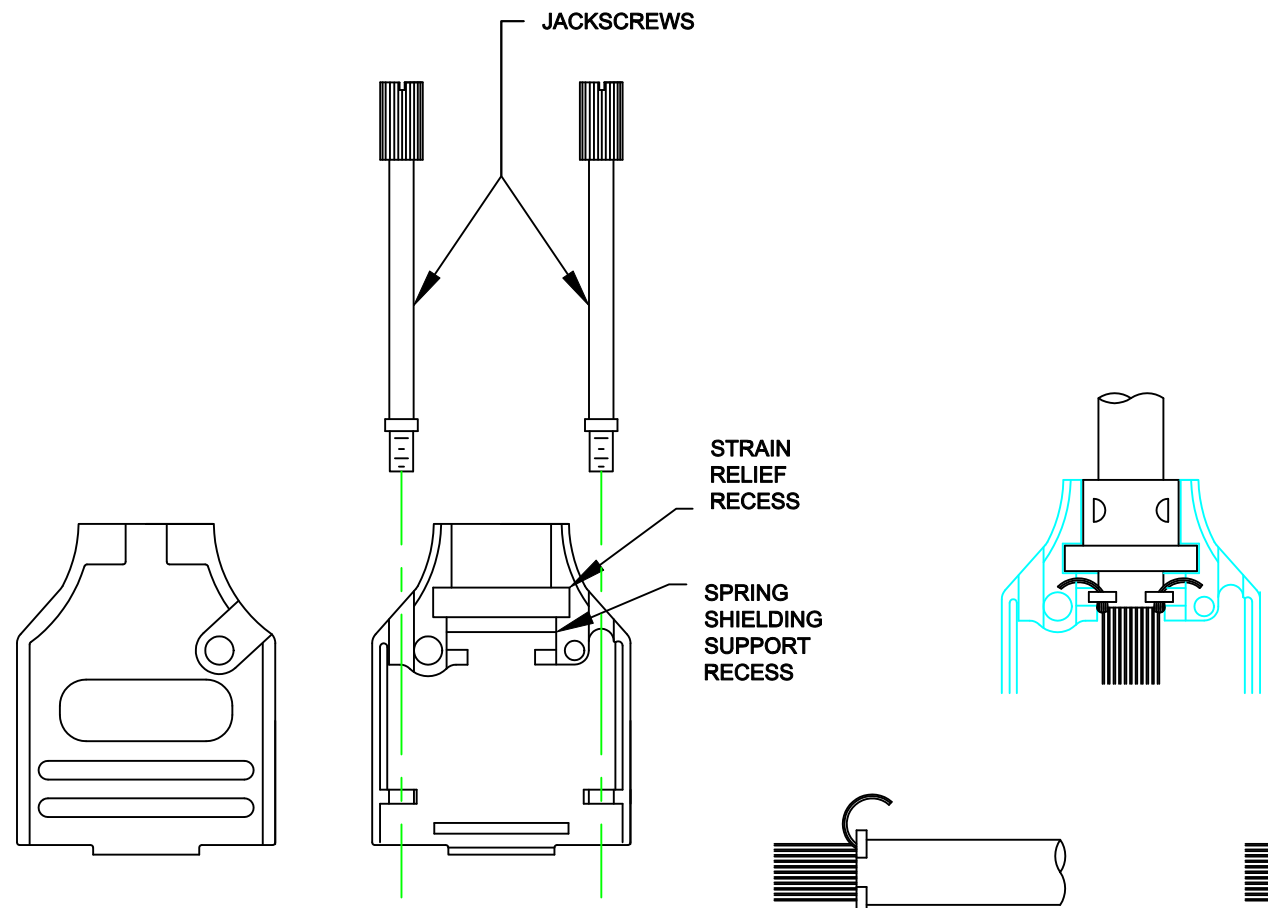

LIGHT BRAIDED CABLE
OR
CABLE WITH FOIL AND DRAIN WIRE

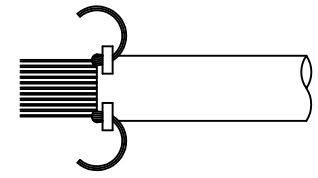

HEAVY BRAIDED CABLE

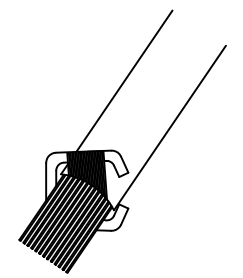

GENERAL VIEW

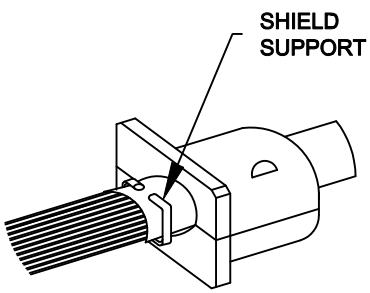

SHIELD NOT SHOWN FOR CLARITY

RoHS COMPLIANT

DIE CAST & METALIZED PLASTIC

	THESE DRAWINGS AND SPECIFICATIONS ARE THE PROPERTY OF NorComp AND SHALL NOT BE REPRODUCED, COPIED OR USED AS THE BASIS FOR THE MANUFACTURE OF SALE OF APPARATUS WITHOUT WRITTEN PERMISSION.		DRAWN: C. SMITH	DATE: 03-20-06
			CHECKED: X	DATE: X
<h1>NorComp</h1>		SCALE: N.T.S.	SHEET 2 OF 4	REV 1
		DWG NO. BACKSHELL - 970 SERIES		

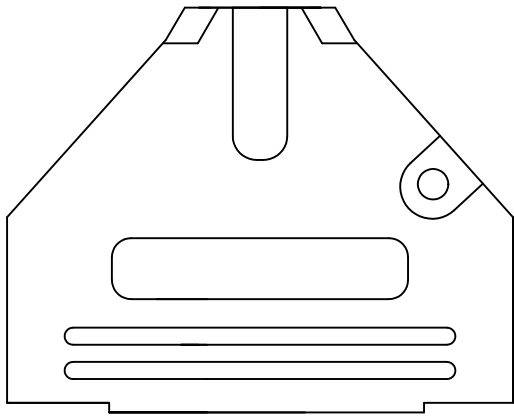

COVER HOOD

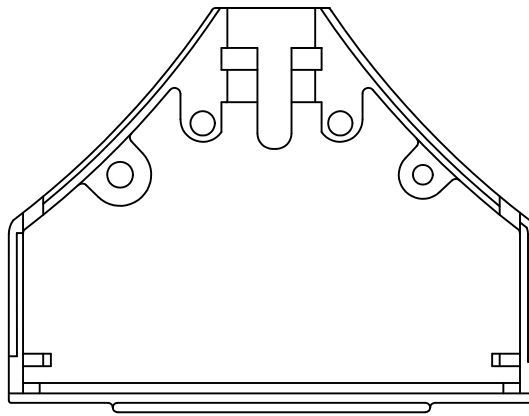

BASE HOOD

ASSEMBLY INSTRUCTIONS:

1. PREPARE CABLE ENDS, CONNECT TO CONNECTOR
2. SELECT CORRECT INSERT SIZE FOR CABLE BEING USED, PLACE LONG INSERT INTO RECESS AREA OF BASE HOOD
3. PLACE SHORT INSERT INTO RECESS OF COVER HOOD
4. PLACE CABLE INTO INSERT IN BASE HOOD. USING EITHER THE FLAT OR CURVED STRAIN RELIEF (OR BOTH), CLAMP THE CABLE MAKING SURE THE JACKET IS BELOW THE STRAIN RELIEF
5. IF CABLE IS SHIELDED, FOLD SHIELD AND/OR GROUND WIRE BACK UNDER STRAIN RELIEF. CUT OFF ANY EXCESS WIRE SO IT DOES NOT STICK OUT OF THE STRAIN RELIEF
6. PLACE THE THUMBSCREWS INTO THE BASE HOOD
7. PLACE THE COVER HOOD ON TOP OF THE BASE HOOD, MAKING SURE NO WIRES ARE PINCHED
8. HOLDING THE HOODS TOGETHER, SCREW THE TWO HOOD SECTIONS TOGETHER USING THE SCREWS PROVIDED

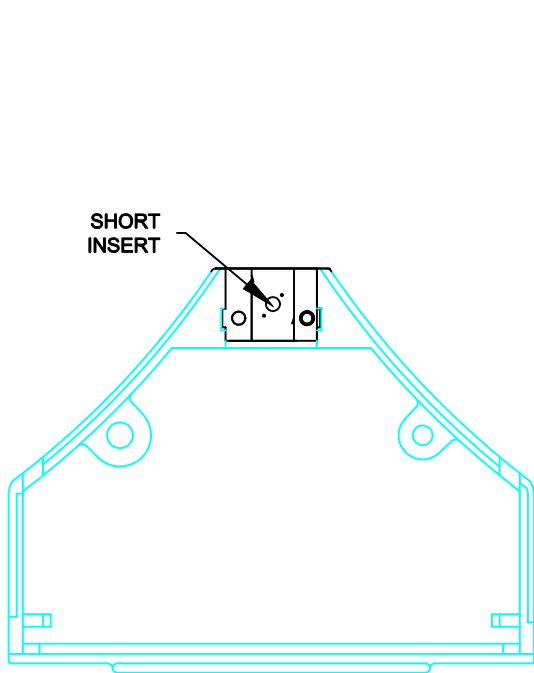

ITEM No. 3

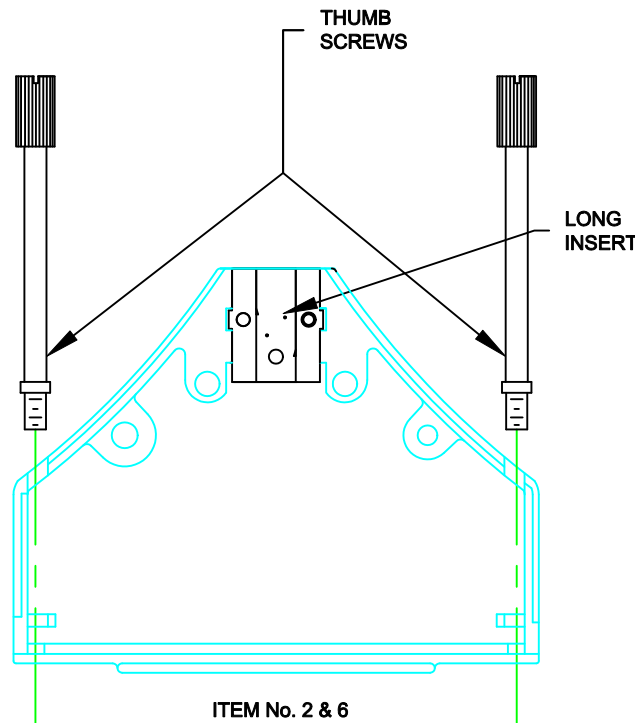

ITEM No. 2 & 6

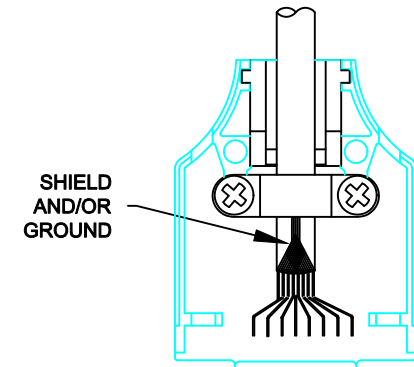

ITEM No. 4 & 5

DIE CAST

DO NOT SCALE FROM DRAWING



THESE DRAWINGS AND SPECIFICATIONS ARE THE PROPERTY OF NorComp AND SHALL NOT BE REPRODUCED, COPIED OR USED AS THE BASIS FOR THE MANUFACTURE OF SALE OF APPARATUS WITHOUT WRITTEN PERMISSION.

DRAWN: M. SIGMON		DATE: 4-25-12	
CHECKED:		DATE:	
SCALE: N.T.S.	SHEET 3	OF 4	REV 1
DWG NO. BACKSHELL - 970-050-030R121			

RoHS COMPLIANT

NorComp

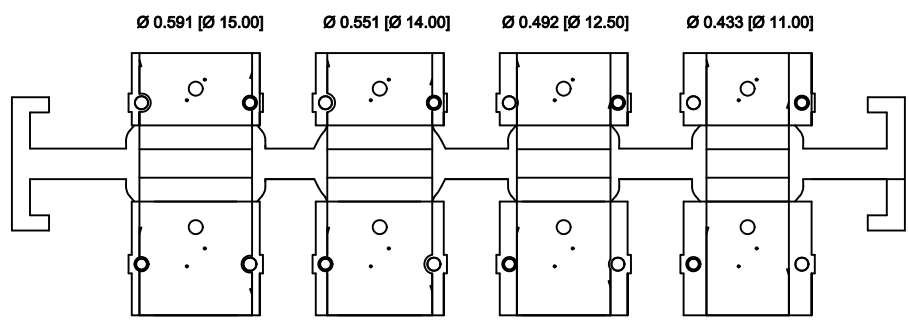

PLASTIC INSERTS

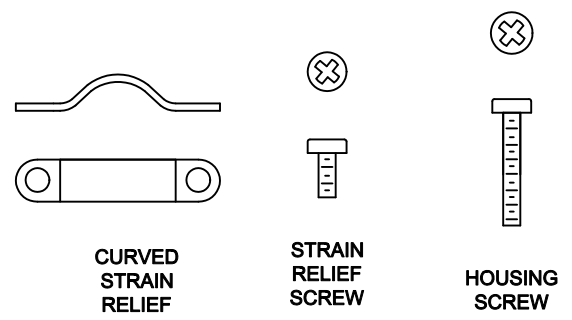

CURVED STRAIN RELIEF

STRAIN RELIEF SCREW

HOUSING SCREW

DIE CAST

DO NOT SCALE FROM DRAWING

	THESE DRAWINGS AND SPECIFICATIONS ARE THE PROPERTY OF NorComp AND SHALL NOT BE REPRODUCED, COPIED OR USED AS THE BASIS FOR THE MANUFACTURE OF SALE OF APPARATUS WITHOUT WRITTEN PERMISSION.		DRAWN: M. SIGMON	DATE: 4-25-12
			CHECKED:	DATE:
<h1>NorComp</h1>		SCALE: N.T.S.	SHEET 4 OF 4	REV 1
		DWG NO. BACKSHELL - 970-050-030R121		

RoHS COMPLIANT